

Oil-free Turbomachinery

with active magnetic bearing technology

Active magnetic bearings

Enabling oil-free turbomachinery

Active magnetic bearings (AMB) are electromagnetic, mechatronic systems used to maintain the relative position between a machine's rotating assembly (rotor) and stationary components (stator)

Advantages of AMB over traditional oil bearings

- No contact friction or components wear
- No oil lubricant or Lube-oil system required, no flushing
- Compact skirts and footprint, weight reduction
- Lower mechanical losses
- Environmentally friendly solution
- Proven solution with high reliability and availability
- Longer asset life and light maintenance
- Enhanced built-in machine monitoring capabilities
- Ready for unmanned operations, remote analysis, big data

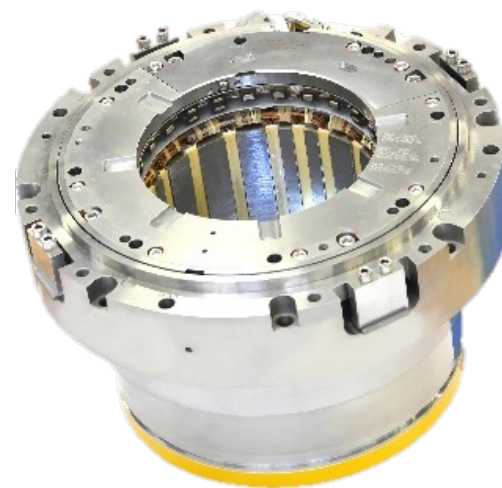


Image courtesy of
SKF S2M Magnetic Bearings



After more than 30 years of collaboration, we signed a new partnership in 2016 based on exchange, development, and growth. It lets Baker Hughes use SKF's leading magnetic bearing technologies from front-end engineering design to installation, testing, and service. The partnership also provides the basis for future collaboration, to widen the scope of AMB application to other turbomachinery.

Baker Hughes oil-free products with AMB

Turboexpanders

- More than 30 turboexpanders manufactured so far
- 5 AMB sizes for turboexpander frames 20 to 60
- NACE compliant applications for sour gas



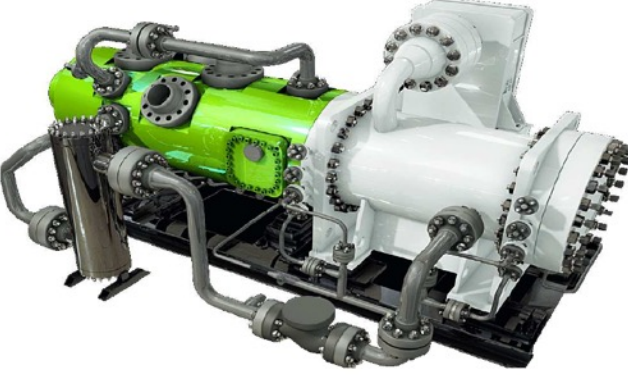
Turboexpander

Centrifugal compressors

- 5 compressor units on AMB developed in early 1990s
- Zero-emission* ICL motocompressor system developed in 2006, and over 50 ICL units sold since
- Blue-C subsea moto compressor full scale demonstrator fully tested in customer facilities in 2015
- 10+ high-speed, oil-free motocompressors with AMB for offshore applications delivered to date



High-speed, direct-drive (HSDD) motocompressor



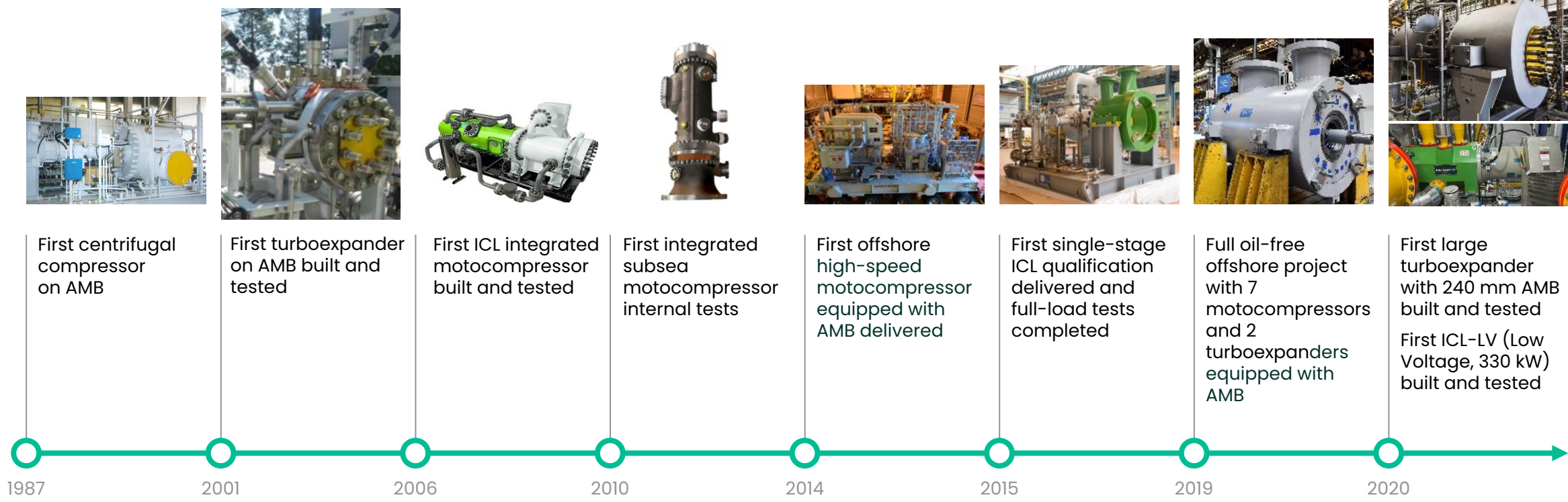
ICL



Image courtesy of SKF S2M Magnetic Bearings

* Zero-emissions during operation and pressurized stand by. Being an electrical driven compressor, emissions are proportional to electrical grid power generation emissions. In case of green electrical power, ICL is removing up to 99% of emissions compared to gas-fired solutions.

Baker Hughes: AMB pioneer



Oil-free, high-speed motocompressors

Compact AMB-motocompressor compatible with sour process gas

Compact and light

- Footprint reduction up to 50%
- Weight reduction up to 50%
- High-speed, direct-drive (HSDD) AMB, air-cooled solution
- Elimination of lube-oil console, gearbox, and low-speed coupling from package

Compatible with sour and severe gas

- No specific limitation vs. gas corrosive contaminants
- NACE-compliant applications for sour gas

Perfect fit for large-scale LNG and pipeline applications

Oil-free

- Enabled by AMB technology
- Removing oil consumption and associated oil spill or fire risks

Low noise

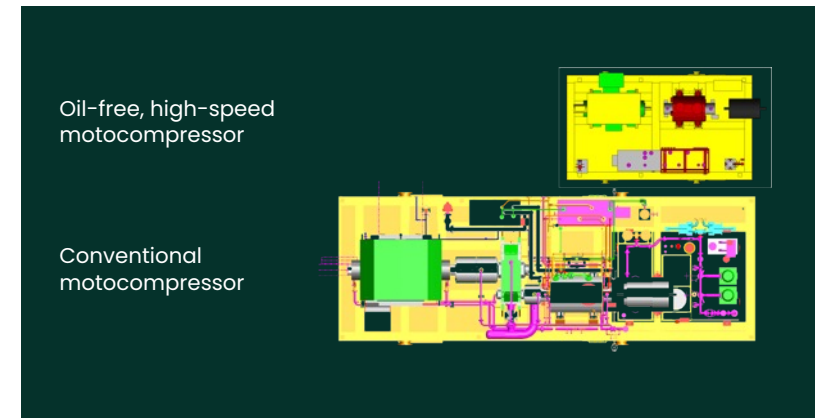
- Elimination of gearbox (key noise contributor in conventional package)

High operational flexibility

- Wider operating range (up to 30-105% speed)
- High efficiency due to reduced mechanical losses
- Always ready to start (no oil system start-up required)
- Solution ready for unmanned operation



Compressor and high-speed driver in separate casings



ICL: Integrated Compressor Line



Compressor and high-speed driver embedded in same pressurized casing

Compact

- Footprint reduction up to 50%
- High-speed, direct-drive and gas-cooled solution
- Elimination of lube-oil console, seal-gas panel, and gearbox from package

Zero emission

- Carbon footprint reduction by avoiding dry gas seal leakage
(40k Nm³/y of natural gas leakage represents ~700t CO₂ equiv. for a typical pipeline compression train)
- Hermetic solution intrinsically safe without seal gas system risks and maintenance

Oil-free

- Enabled by AMB technology
- Removing oil consumption and associated oil spill or fire risks

Low noise

- Typical reduction of 3 dB(A)
- Encapsulation in pressure-containing casing providing heavy noise attenuation
- Elimination of gearbox (key noise contributor in conventional package)

High operational flexibility

- Wider operating range (up to 30–105% speed)
- Efficiency remaining high across full operating range
- Low utility consumption requested (no N₂, limited Air and Low Voltage)
- Unlimited pressurized standstill: no flaring,, or major auxiliaries running
- Always ready to start: 5 minutes max warm-up time
- Solution ready for unmanned operation



Conventional compressor train

ICL

ICL-LV (low voltage)

To manage low-pressure wet gas for needs below 1 MW

Compact and light

- No wear parts involved with centrifugal stage compression
- Magnetic bearings enable frictionless rotor rotation
- No need for lube oil system, reducing auxiliaries
- No need for dry gas seals and associated auxiliaries

Compact and maintenance friendly

- Easy handling of components
- Cartridge pull-out assembly containing motor and compressor internals for fast and easy swap
- Almost no civil work for package installation
- Easy integration in transportable modules

Reduced environmental footprint

- Zero leakage solution
- No nitrogen utility consumption required
- No oil consumption or associated oil spill or fire risks
- Low noise solution due to encapsulation and compression technology



ICL-LV: low-voltage solution with all the benefits of ICL

Typical applications



Recycling of vent gas from industrial processes



Valorization of formerly flared associated gas



Decentralized gas gathering

ICL-LV is designed to help energy industry to reduce emissions and operate more efficiently leveraging above opportunities.

Oil-free turboexpanders

Simple design exploiting active magnetic bearing's advantages

Compact and light

- Compact skid design with simplified system
- Easy to maintain

Zero emission for sweet process gas

- Carbon footprint reduction by avoiding dry gas seal (DGS) leakage
- Hermetic solution intrinsically safe with no need of continuous venting/flaring

Oil-free

- Enabled by AMB technology
- Removing oil consumption and associated oil spill or fire risks

High operational flexibility

- Always ready to start (no oil system start-up required)
- Solution ready for unmanned operation
- Wider operating range though built-in inlet guide vane regulation

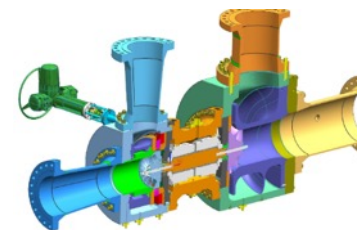
Adaptability in customer plant integration

- Zero-leakage solution for turboexpander-driven compressor or generator
- Delivering gas pressure energy or electric power depending on customer needs

Available with dry gas seal for harsh environments



Image courtesy of SKF S2M Magnetic Bearings



Oil-free expander compressor



Oil-free expander generator

SKF-S2M active magnetic bearing principle

- The magnetic bearing is made of electromagnets (1) that attract the rotor (2) towards the central rotation axis. It is contactless with a radial clearance of 0.5 to 1 mm
- The rotor position is measured and controlled by position sensors (3), through a digital control (5) and power current amplifiers (4)
- Auxiliary bearings (6): prevents mechanical contact between the rotor and active parts of the stator
- The active magnetic bearing is constantly managed through a feedback control loop:

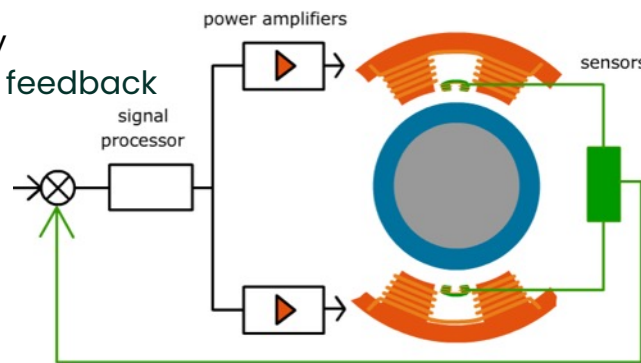
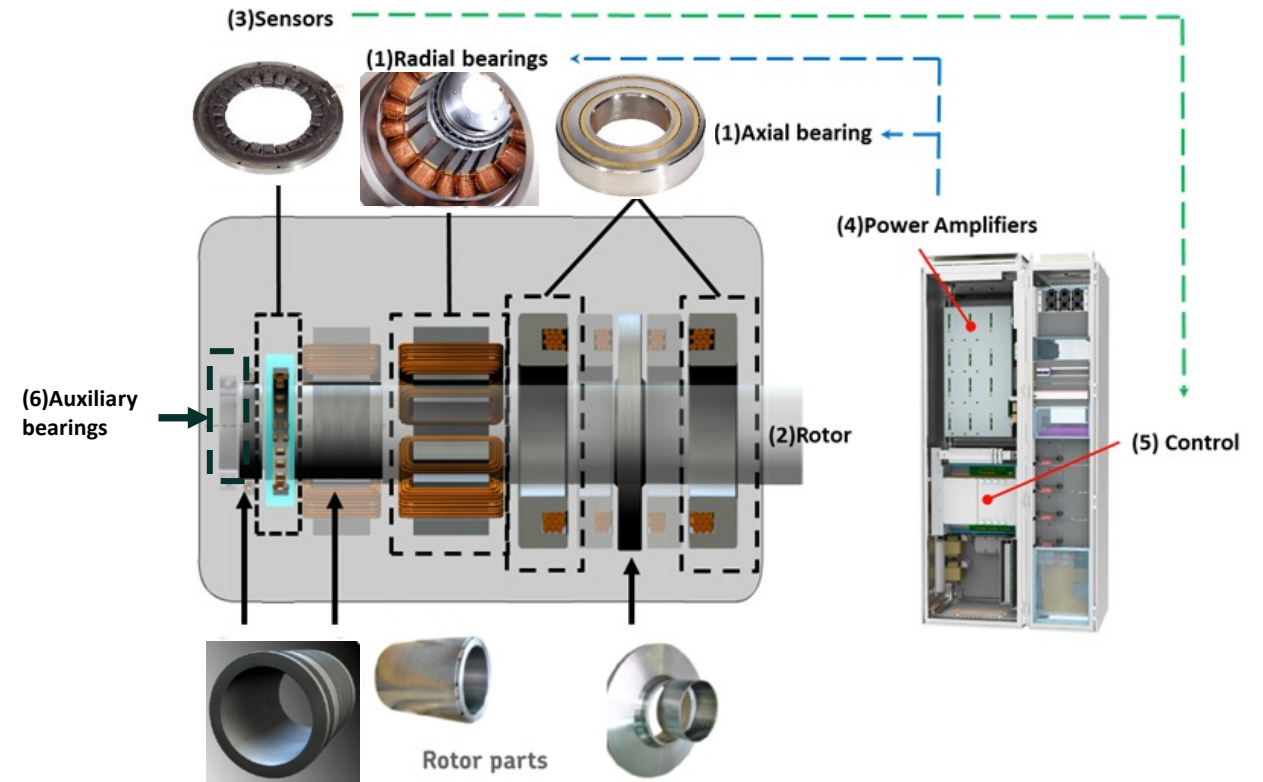


Image courtesy of SKF S2M Magnetic Bearings

- SKF S2M bearings follow the **API617** and the **ISO 14839 standards** dedicated to magnetic bearings. SKF S2M is a member of both committees



With courtesy of SKF S2M Magnetic Bearings

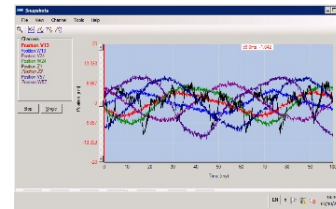
Monitoring and diagnostic through the AMB control panel

The SKF MBScope® software suite is an advanced diagnostic and servicing interface to the E300V2 control cabinet used for AMB tuning, troubleshooting, and high-sampling data acquisition and diagnostics.

There are 2 levels of licenses that allow the end user to choose the functionalities of monitoring. MBScope can monitor equipment health with display of high-resolution digital data through real-time snapshots in time, frequency 3D, or polar basis.

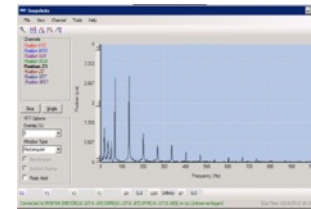


Image courtesy of SKF S2M Magnetic Bearings



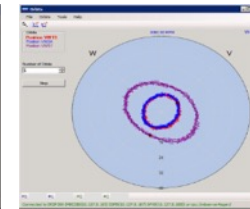
Waterfall view

For simple analyzing



Event viewer

To view and store sampled data collected and event log

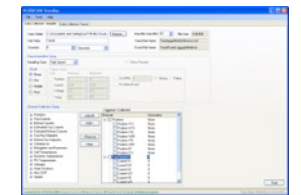
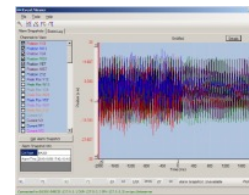
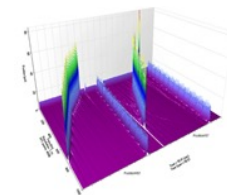


Automatic diagnostics

- Bearing insulation
- Auxiliary bearings
- UPS batteries
- Electronics

Snapshots

Sampled data are displayed in real time. Signals can be viewed in the time or frequency domains, as orbits or waterfall, or as statistics in tabular form.



Trending

Acquisition tool for continuous real-time data recording

Axis	Min Tolerance (gm)	Max Tolerance (gm)	Previous Measurement (gm)	New Measurement (gm)	Status
R1,V	240	280	253	254	OK
R1,W	240	280	253	275	OK
R2,V	210	280	271		OK
R2,W	210	280	258		OK
R3,V	210	280	249	274	OK
R3,W	210	280	251	259	OK
Z	300	600	382	650	Over tolerance