



# Flame Sensor

## Operation and Maintenance Manual

Applicable to part numbers:

**RS-FS-9001**

 <b>Reuter-Stokes</b> <small>a Baker Hughes business</small>	NO.:	FS-9001OM		
	PAGE:	ii	OF	8
RS-FS-9001 User Manual	REV.:	U		

---

# **FS-9001OM**

## **Revision: U**

### **June 2023**

**8499 Darrow Road**

**Twinsburg, OH 44087**

	NO.:	FS-9001OM		
	PAGE:	iii	OF	8
RS-FS-9001 User Manual	REV.:	U		

---

This document and all information and expression contained herein are the property of Reuter-Stokes, LLC. and are provided to the recipient in confidence on a “need to know” basis. Your use of this document is strictly limited to a legitimate business purpose requiring the information contained therein. Your use of this document constitutes acceptance of these terms.

 <b>Reuter-Stokes</b> <small>a Baker Hughes business</small>	NO.:	FS-9001OM		
	PAGE:	iv	OF	8
RS-FS-9001 User Manual	REV.:	U		

---

Copyright © 2023 Baker Hughes Company. All rights reserved.

Contains Proprietary Information.

 <b>Reuter-Stokes</b> <small>a Baker Hughes business</small>	NO.:	FS-9001OM		
	PAGE:	v	OF	8
RS-FS-9001 User Manual	REV.:	U		

---

This page intentionally left blank.

 <b>Reuter-Stokes</b> <small>a Baker Hughes business</small>	NO.:	FS-9001OM		
	PAGE:	vi	OF	8
RS-FS-9001 User Manual	REV.:	U		

---

## CONTENTS

Contents..... vi

List of Figures.....vii

List of Tables .....viii

Important Information .....1

    Warnings and Cautions ..... 3

General Description ..... 4

Specifications..... 5

Interconnecting Cable..... 6

Mechanical Dimensions..... 8

Sensor..... 9

Installation ..... 11

    Mechanical..... 11

    Electrical.....14

    Connector Pinout.....15

    Sensor Checkout .....16

    Controller Setup.....17

Maintenance .....18

Troubleshooting.....19

    Customer Support Centers.....22

	NO.:	FS-9001OM		
	PAGE:	vii	OF	8
RS-FS-9001 User Manual	REV.:	U		

---

## LIST OF FIGURES

Figure 1: 4-20 mA Interconnect Cable .....	6
Figure 2: Housing Side View.....	8
Figure 3: Housing Front View.....	8
Figure 4: Flame Sensor Wiring Diagram .....	10
Figure 5: Water Cooling Jacket Installation Instructions.....	12

 <b>Reuter-Stokes</b> <small>a Baker Hughes business</small>	NO.:	FS-9001OM		
	PAGE:	viii	OF	8
RS-FS-9001 User Manual	REV.:	U		

---

## LIST OF TABLES

Table 1: Available 4-20 mA Cables.....7

Table 2: Connector Pinout.....15

Table 3: Troubleshooting.....21



	NO.:	FS-9001OM		
	PAGE:	1	OF	22
RS-FS-9001 User Manual	REV.:	U		

---

## IMPORTANT INFORMATION

All content and material in this manual (including, without limitation, text, design, graphics, logos, icons, images, code and software, as well as the selection and arrangement thereof) is confidential and proprietary, the exclusive property of and owned by Reuter-Stokes, Inc. and is protected by copyright, trademark and other applicable laws. Any use of content and material in this manual, including but not limited to the modification, distribution, transmission, performance, broadcast, publication, uploading, licensing, reverse engineering, transfer or sale of, or the creation of derivative works from, any material, information, software, products or services obtained from the content and material in this manual, or use thereof for purposes competitive to Reuter-Stokes, Inc., is expressly prohibited.

While every attempt has been made to assure the completeness, accuracy and timeliness of the content and material in this manual, it is provided on an “as is” and “as available” basis. Reuter-Stokes, Inc. expressly disclaims all warranties of any kind, whether express or implied, including but not limited to the implied warranties of merchantability and fitness for a particular purpose and any warranties that the content and material in this manual is non-infringing as well as warranties implied from a course of performance or course of dealing, the materials in this manual will be error-free, or that the materials in this manual will be complete, accurate or timely. No advice or information, obtained by you from Reuter-Stokes, Inc. or through the content and material in this manual shall create any warranty of any kind. Reuter-Stokes, Inc. does not make any warranties or representations regarding the use of the content and material in this manual in terms of its completeness, the use of the content, and material in this manual in terms of its completeness, correctness, accuracy, adequacy, usefulness, timeliness, reliability or otherwise.

	NO.:	FS-9001OM		
	PAGE:	2	OF	22
RS-FS-9001 User Manual	REV.:	U		

---

You acknowledge and agree that you assume full responsibility for your use of the content and material in this manual. You acknowledge and agree that your use of the content and material in this manual is at your own risk. You acknowledge and agree that, to the fullest extent permitted by applicable law, Reuter-Stokes, Inc. will not be liable for any direct, indirect, punitive, exemplary, incidental, special, consequential or other damages arising out of or in any way related to the content and material in this manual, whether based on contract, tort, strict liability, or otherwise. This disclaimer applies, without limitation, to any damages or injury arising from any failure of performance, error, omission, your loss of profits, destruction, and any other tangible or intangible loss.

If this equipment is used in a manner not specified by the manufacturer, the protection provided by the design of this equipment may be impaired.

This instrument contains no operator serviceable parts and should be serviced by qualified personnel only.

 <b>Reuter-Stokes</b> <small>a Baker Hughes business</small>	NO.:	FS-9001OM		
	PAGE:	3	OF	22
RS-FS-9001 User Manual	REV.:	U		

---

## WARNINGS AND CAUTIONS

Throughout this manual, when necessary, notes are used to identify considerations.

Definitions:



---

**WARNING:** IDENTIFIES INFORMATION ABOUT PRACTICES OR CIRCUMSTANCES THAT CAN CAUSE AN EXPLOSION IN A HAZARDOUS ENVIRONMENT, WHICH MAY LEAD TO PERSONAL INJURY OR DEATH, PROPERTY DAMAGE, OR ECONOMIC LOSS.

---



---

**CAUTION:** IDENTIFIES INFORMATION ABOUT PRACTICES OR CIRCUMSTANCES THAT CAN LEAD TO PERSONAL INJURY OR DEATH, PROPERTY DAMAGE, OR ECONOMIC LOSS. CAUTIONS HELP YOU IDENTIFY A HAZARD, AVOID A HAZARD, AND RECOGNIZE THE CONSEQUENCES.

---



---

**NOTE:** IDENTIFIES INFORMATION THAT IS CRITICAL FOR SUCCESSFUL APPLICATION AND UNDERSTANDING OF THE PRODUCT.

---

	NO.:	FS-9001OM		
	PAGE:	4	OF	22
RS-FS-9001 User Manual	REV.:	U		

---

## GENERAL DESCRIPTION

The Flame Tracker is an ultraviolet (UV) light sensitive detector used to measure the intensity of the flame in the combustion cans of a gas turbine. Due to the use of the silicon carbide photodiode, the Flame Tracker is very sensitive to the longer wavelength components of the UV light generated by the flame. These wavelengths penetrate the fog of fuel in the combustion can so the Flame Tracker is significantly more sensitive to the flame than previous technologies, such as Geiger Mueller tubes. Being a UV sensitive device, the Flame Tracker is not sensitive to the infrared light generated by the hot combustion can walls so only the flame's light is detected.

 <b>Reuter-Stokes</b> <small>a Baker Hughes business</small>	NO.:	FS-9001OM		
	PAGE:	5	OF	22
RS-FS-9001 User Manual	REV.:	U		

---

## SPECIFICATIONS

### Mechanical

Body Mount:	AISI316 Stainless Steel
Housing:	AISI304 Stainless Steel (sealed and Argon filled)
Connector	MIL-C-38999 Series III size 15 (5 pin)
Process:	3/4" NPT female
Sensor:	Silicon Carbide photodiode
Window:	Sapphire

### Operating

Sensitivity:	>5 mA @ $1 \times 10^{10}$ photons/in <sup>2</sup> /sec. @ 310 nm
Output:	4 - 20 mA dc, Max < 21 mA
Response time	<25 milliseconds
Power Requirements:	12 - 30 vdc @ > 100 mA
	Terminals isolated from case per EN 60079-11 Section 6.3.12 (500 V <sub>r.m.s.</sub> )
Temperature (ambient):	-40°F to 302°F (-40°C to 150°C)
	455°F (235°C) with specified water cooling
Relative Humidity	100% Non-Condensing
Process Pressure	400 psig (2.8 Mpa)

 <b>Reuter-Stokes</b> <small>a Baker Hughes business</small>	NO.:	FS-9001OM		
	PAGE:	6	OF	22
RS-FS-9001 User Manual	REV.:	U		

## INTERCONNECTING CABLE

The recommended cable to attach the flame sensor to the junction box is the RS-E2-O285PXXX or 362A1053PXX. This is shown in Figure 1. Dimensions shown are in inches (mm) and are reference only.

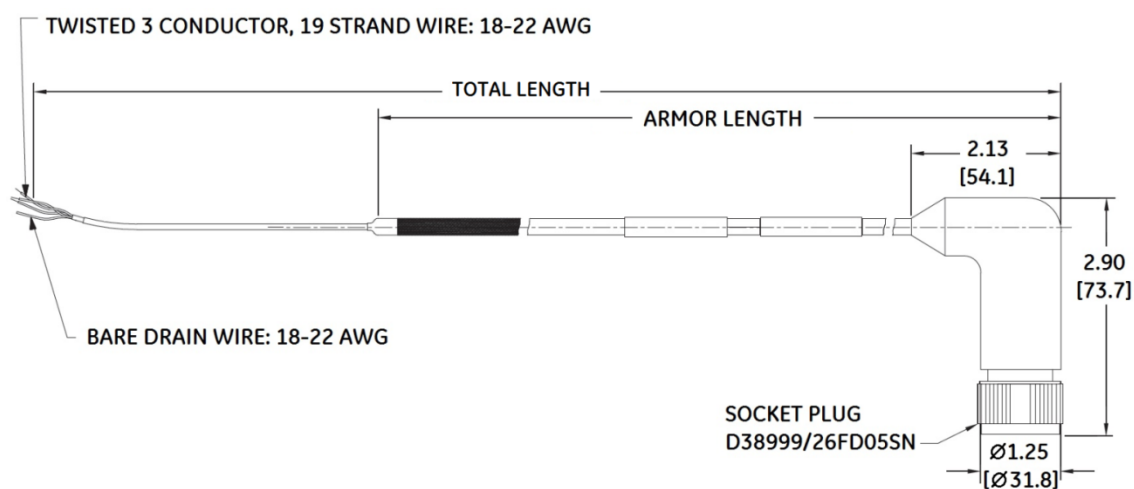

Figure 1: 4-20 mA Interconnect Cable

Connector : MIL-DTL-38999 series III, shell size 15, 5 #16 pins

Voltage (max) : 300 VRMS

Temperature (max) : 482°F (250°C)

 <b>Reuter-Stokes</b> <small>a Baker Hughes business</small>	NO.:	FS-9001OM		
	PAGE:	7	OF	22
RS-FS-9001 User Manual	REV.:	U		

The available cable part numbers are listed in Table 1.

Interconnecting Cable Part Number	Total Length ft [m]	Armor Length in [cm]	Connector Type
RS-E2-0285P001	60-62 [18.3-18.9]	36 [14.2]	Right Angle
RS-E2-0285P003	60-62 [18.3-18.9]	75 [190.5]	Right Angle
RS-E2-0285P004	120-123 [36.6-37.2]	36 [14.2]	Right Angle
RS-E2-0285P021	15-17 [11.9-12.50]	36 [14.2]	Right Angle
RS-E2-0285P011	60-62 [18.3-18.9]	36 [14.2]	Straight
RS-E2-0285P012	120-122 [36.6-37.2]	36 [14.2]	Straight
RS-E2-0285P013	60-62 [18.3-18.9]	96 [243.84]	Straight
RS-E2-0285P010	60-62 [18.3-18.9]	120 [304.8]	Straight

Table 1: Available 4-20 mA Cables

## MECHANICAL DIMENSIONS

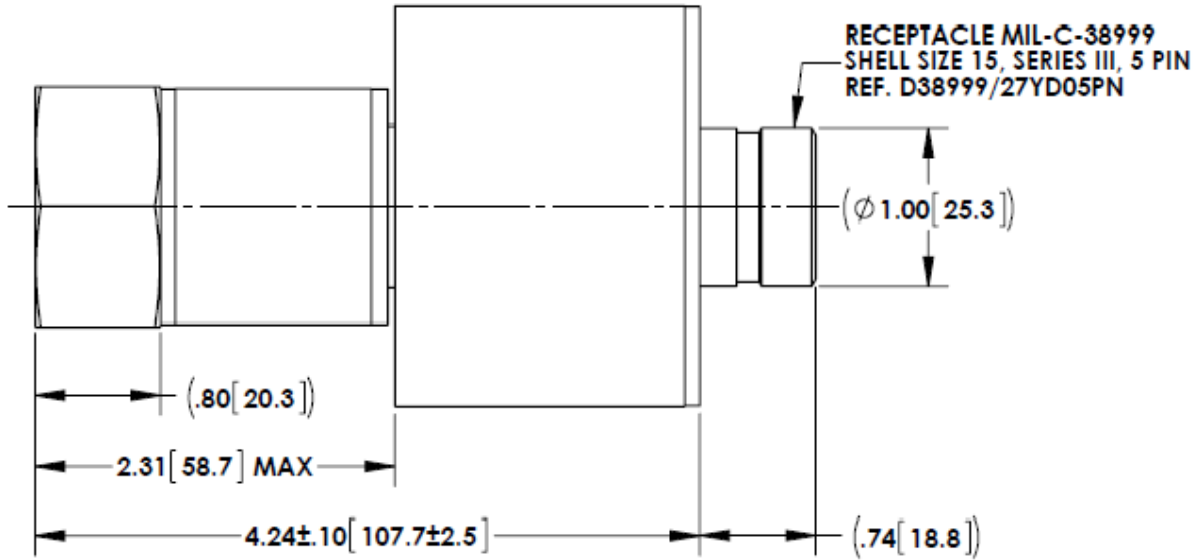

Figure 2: Housing Side View

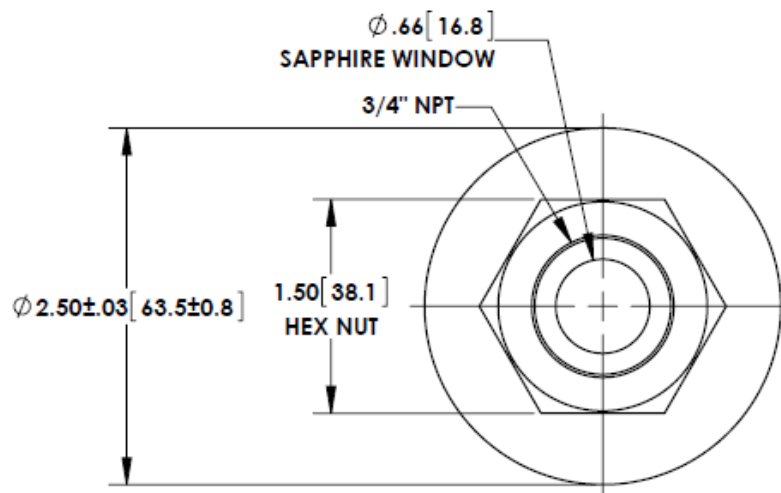



Figure 3: Housing Front View



	NO.:	FS-9001OM		
	PAGE:	9	OF	22
RS-FS-9001 User Manual	REV.:	U		

---

## SENSOR

Figure 4 is a block diagram of the Flame Sensor. The sensor has a sapphire window that is transparent to UV light and can withstand the compressor discharge temperature and pressure. It has a lens inside that focuses the light on a silicon carbide photodiode in a hermetic package. The photodiode is wired to a MOSFET input amplifier. The amplifier has a high initial gain, which automatically shifts to a lower gain in order to accommodate a wide range of input light level without saturating. The sensor regulates the supply current in proportion to the amount of UV light present. Both power and signal are transmitted on the same two wires. The sensor can be powered from a dc voltage between 12 and 30 volts. The sensor is sealed and filled with dry argon.

**SiC FLAME SENSOR**

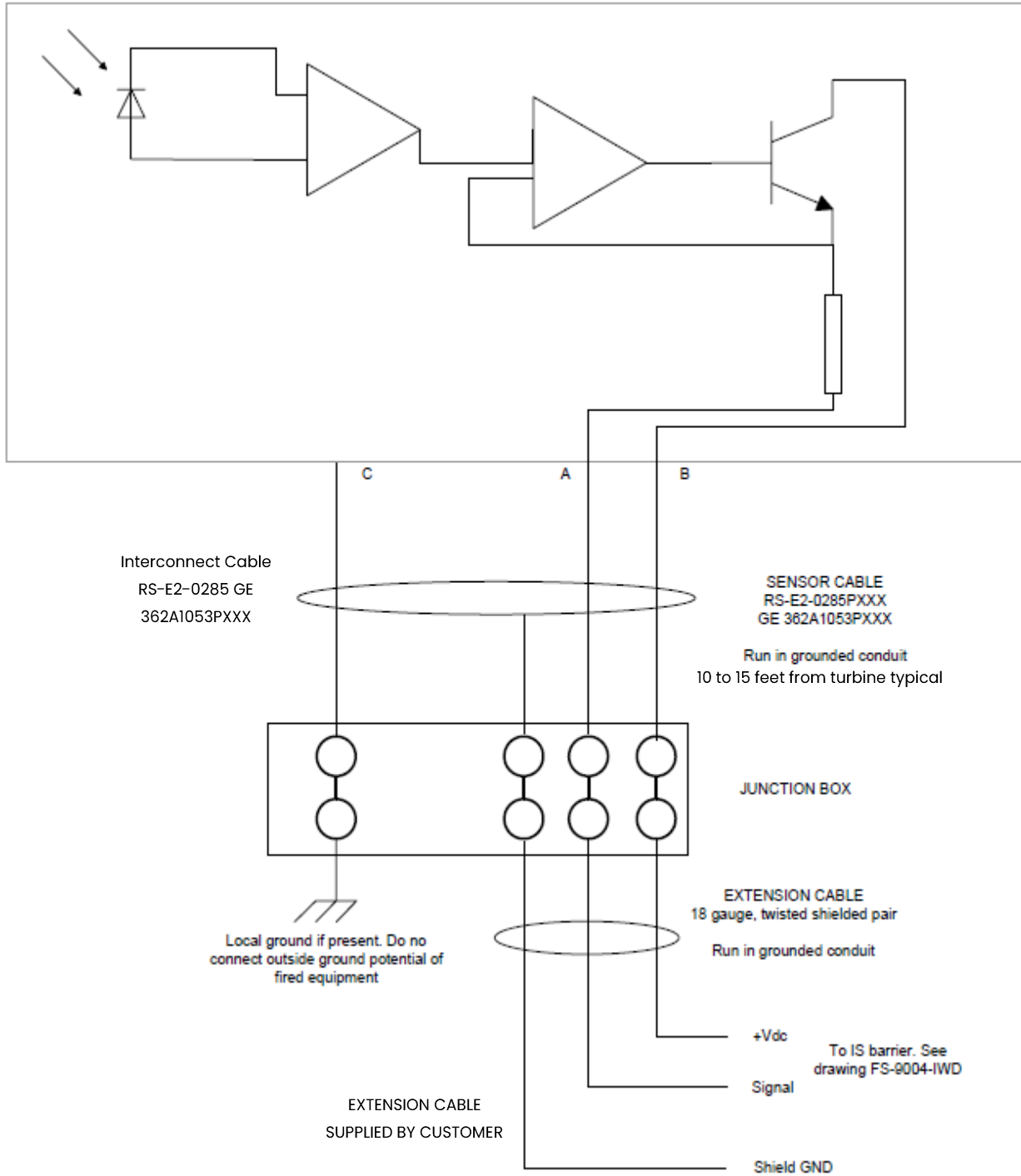



Figure 4: Flame Sensor Wiring Diagram

 <b>Reuter-Stokes</b> <small>a Baker Hughes business</small>	NO.:	FS-9001OM		
	PAGE:	11	OF	22
RS-FS-9001 User Manual	REV.:	U		

---

## INSTALLATION

### MECHANICAL

The maximum operating temperature for the flame sensor is 302° F (150° C). If the peak ambient temperature at the location of the sensor exceeds this then cooling will be required. There are three methods available for cooling:

- Water-cooling
- Air-cooling with ambient air
- Air-cooling with pressurized air.

Water-cooling requires the use of a water-cooling coil Part Number SP-566, GE Part Number 353B3490G001. The water-cooling coil requires water at a temperature of 50° F to 135° F (10° C to 57° C) at a flow rate of 1.0 gpm (3.8 lpm) per sensor. When using water-cooling the flame sensor can be operated to an ambient temperature of (455°F) 235°C.

Air-cooling with ambient air can be used in installations where the enclosure is cooled with forced air. This would be typical of LM2500 and LM6000 aircraft engine applications. The air velocity at the sensor must be 5 ft/sec (1.5 m/sec), or greater, at a temperature of 50° F (10° C), or less, above outside ambient. Under these conditions the sensors will operate at outside ambient temperatures up to 140° F (60° C).

Air-cooling with pressurized air requires the use of Air-Cooling Can (Reuter-Stokes Part Number RS-E2-0259 or GE Part Number 07482SOCNL44821P01). The Air-Cooling Can is installed in the same manner as the water-cooling coil. The Air-Cooling Can requires 25 psi (172.3 kPa) minimum at 120° F (49° C) maximum.

Do not complete step 2 of the following instructions at this time. Leave the sensors installed hand tight until after the sensor checkout described in Section 3.3.

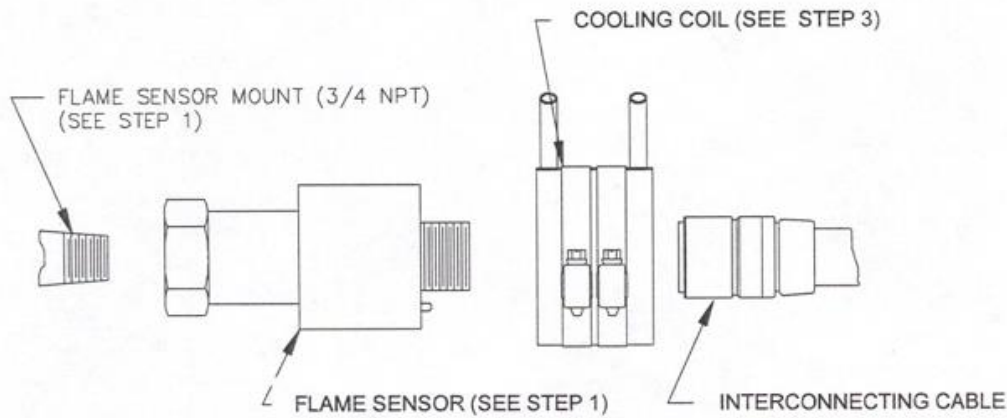



Figure 5: Water Cooling Jacket Installation Instructions

1. Ensure that the cooling coil is not attached to the flame sensor during installation or removal of the sensor. The cooling coil can apply an unwanted torque and cause disassembly and malfunction of the flame sensor.
2. Apply a small amount of Never-Seez PN NG-165 to threads of sight tube prior to installation. Be sure the Never-Seez applied to the sight tube is minimal and only applied below the 2<sup>nd</sup> thread. If Never-Seez is applied to the face of the sight tube, upon heating, it can fog the window of the Flame Sensor
3. Inspect the window and clean with Isopropanol-soaked swab. If required install hand tight (3-4 Full turns) tighten with a wrench approximately 2.5 turns. Tighten further as required to align keys on cable connector with slots in sensor connector
4. Slide cooling coil over Flame Sensor major diameter and orient tubes on the coil as required for assembly. Tighten clamps 50-60 in. lbs. Install Swagelok fittings re-torque clamps to 50-60 in. lbs. after first shut down

 <b>Reuter-Stokes</b> <small>a Baker Hughes business</small>	NO.:	FS-9001OM		
	PAGE:	13	OF	22
RS-FS-9001 User Manual	REV.:	U		



**Note:** 50 - 60 in. lbs. = 5.6 - 6.8 Nm. When installing the Water-Cooling Coil, ensure that the edge of the Sheet Metal Band is not in contact with the cooling tubes. This will ensure that no rubbing or fretting of the cooling tubes by the band's edge will occur during turbine operation.

	NO.:	FS-9001OM		
	PAGE:	14	OF	22
RS-FS-9001 User Manual	REV.:	U		

---

## ELECTRICAL

The sensors are connected to the turbine junction box with connector cable RS-E2-0285PXXX or 362A1053PXXX. The RS-E2-0285 consists of black, white and green wires twisted and shielded. All wiring must be in grounded conduit. The green wire must be connected to earth ground at the junction box. Do not connect the shields to each other or to earth ground at any location. The shields should be individually jumped through all junction boxes and connected to the proper ground terminal at the Controller. The polarity of the cable is as follows; white is positive and black is negative/signal return. Reverse polarity will not damage the sensor. Signal cable from the junction box to the Controller should be 18 gauge (1.02 mm) twisted shielded pair. The extension cable from the junction box to the Controller is the customer's responsibility.

 <b>Reuter-Stokes</b> <small>a Baker Hughes business</small>	NO.:	FS-9001OM		
	PAGE:	15	OF	22
RS-FS-9001 User Manual	REV.:	U		

---

## CONNECTOR PINOUT

The pinout for the power connector is shown in Table .

Pin	Signal	Wire Color for RS-E2-0285PXXX cable
A	-	Black
B	+	White
C	Ground	Green
D	Not used	n/a
E	Not used	n/a

Table 2: Connector Pinout

 <b>Reuter-Stokes</b> <small>a Baker Hughes business</small>	NO.:	FS-9001OM		
	PAGE:	16	OF	22
RS-FS-9001 User Manual	REV.:	U		

---

## SENSOR CHECKOUT

Disconnect the sensors and unscrew them from the turbine. Plug the sensor cables back into each of the sensors. Apply power to the sensors. Check the current values at the controller for each of the sensors. The sensors are sensitive to light, and may have some reading, depending on the ambient light level. Test each sensor by covering the port to see the no light intensity signal, and with a flashlight to see a positive reading. With no light the reading should be 3.7 to 4.1 milliamps, while with most flashlights the reading should be above 8 milliamps. An LED flashlight may not work for this application. Variations in flashlight type, strength, or battery voltage may cause variation in signal output. UV inspection flashlights with a UV wavelength near 310 nm work best. The flashlight test is intended as a field test for general functionality only and is not a controlled or quantitative test. If a sensor is outside these rough limits see the Troubleshooting section.

Disconnect the sensor cables and reinstall the sensors according to the Installation section. Make sure the sapphire window is clean; if it needs cleaning, do this according to the maintenance instructions in the Maintenance section. Check that all sensors are reading between 3.7 and 4.1 milliamps.



 <b>Reuter-Stokes</b> <small>a Baker Hughes business</small>	NO.:	FS-9001OM		
	PAGE:	17	OF	22
RS-FS-9001 User Manual	REV.:	U		

---

## CONTROLLER SETUP

The Flame Sensor provides a minimum output of 5 milliamps when exposed to the minimum flame intensity specified in GE specification number 362A1052. In most turbines, the set point for flame off should be set to 6.25%, which is equal to 5 milliamps. The set point for flame on should be 10%, which equals 5.6 milliamps. If the intensity levels are too low for these settings their may be other problems. Low intensity levels may be a sign of other problems. Refer to the Troubleshooting section.

 <b>Reuter-Stokes</b> <small>a Baker Hughes business</small>	NO.:	FS-9001OM		
	PAGE:	18	OF	22
RS-FS-9001 User Manual	REV.:	U		

---

## MAINTENANCE



**WARNING:** Do not disconnect while the circuit is energized (live) unless the area is known to be non-hazardous. (RISQUE D'EXPLOSION. NE PAS CONNECTER OU DÉBRANCHER LE CÂBLE LORSQU'IL EST ÉNERGÉTIQUE)



**CAUTION:** The operating temperature range of the Flame Sensor is -40°F to 302°F (-40°C to 150°C). Do not attempt to work on the Flame Sensor or the cable until they have reached to a safe handling temperature.

The Flame Sensor output will deteriorate as the lens becomes dirty. It is recommended, when initially installed, that the signal level be recorded during normal operation. During subsequent running, the signal level should be compared with the initial values. If a significant reduction in the signal level is noticed, then it is recommended that the lens be cleaned at the next opportunity (with the turbine shut down and cold). Clean the lens with isopropyl alcohol or other residue free solvent compatible with Sapphire. In order to reduce the risk of galling, an anti-seize compound should be applied to the mounting thread prior to reinstallation of the sensor.

 <b>Reuter-Stokes</b> <small>a Baker Hughes business</small>	NO.:	FS-9001OM		
	PAGE:	19	OF	22
RS-FS-9001 User Manual	REV.:	U		

---

## TROUBLESHOOTING



**WARNING:** Do not disconnect while the circuit is energized (live) unless the area is known to be non-hazardous. (RISQUE D'EXPLOSION. NE PAS CONNECTER OU DÉBRANCHER LE CÂBLE LORSQU'IL EST ÉNERGÉTIQUE)



**CAUTION:** The flame sensor operates at extreme temperatures. Do not attempt to work on the flame sensor until it has reached a safe handling temperature.

Problem	Cause	Solution
No current flows	<ol style="list-style-type: none"> <li>1. Reversed polarity</li> <li>2. Open wire</li> <li>3. No 12-30V supply</li> </ol>	<ol style="list-style-type: none"> <li>1. Change polarity at junction box, flame sensor module (if applicable – Mark V and below)</li> <li>2. Check connections at junction box, flame sensor module (if applicable – Mark V and below)</li> <li>3. Check voltage supply to ensure power is reaching sensor</li> </ol>
Low sensitivity during checkout or operation	<ol style="list-style-type: none"> <li>1. Dirty window</li> <li>2. Grounded cable</li> <li>3. Tube mount not torqued</li> </ol>	<ol style="list-style-type: none"> <li>1. Clean window (Section 4.0)</li> <li>2. Check cables for grounds</li> <li>3. Check torque, torque to specified values</li> </ol>
Low flame intensity signal during operation	<ol style="list-style-type: none"> <li>1. Misalignment of the sensor mount</li> <li>2. Dirty window</li> <li>3. Tube mount not torqued</li> </ol>	<ol style="list-style-type: none"> <li>1. Check the squareness of all flanges and pipes of the sensor mount.</li> <li>2. Verify that the sensors have a clear view of the flame.</li> <li>3. Ensure tube mount is torqued</li> </ol>

 <b>Reuter-Stokes</b> <small>a Baker Hughes business</small>	NO.:	FS-9001OM		
	PAGE:	21	OF	22
RS-FS-9001 User Manual	REV.:	U		

<p>Periodic low reading on secondaries of DLN1 turbines</p>	<ol style="list-style-type: none"> <li>1. Condensation on the sensor window that can occur under high humidity situations.</li> </ol>	<ol style="list-style-type: none"> <li>1. A shorter mount tube (PN# EI-0058P002), available from BHGE Reuter Stokes may improve this condition. Please contact Reuter Stokes for further information.</li> </ol>
<p>No flame indication</p>	<ol style="list-style-type: none"> <li>1. Cable connection open</li> <li>2. Open wire</li> <li>3. No-12-30V supply</li> </ol>	<ol style="list-style-type: none"> <li>1. Check connections at junction box, flame sensor module (if applicable – Mark V and below)</li> <li>2. Check voltage supply to ensure power is reaching sensor</li> <li>3. Check voltage supply to ensure power is reaching sensor</li> </ol>

Table 3: Troubleshooting

 <b>Reuter-Stokes</b> <small>a Baker Hughes business</small>	NO.:	FS-9001OM		
	PAGE:	22	OF	22
RS-FS-9001 User Manual	REV.:	U		

---

## CUSTOMER SUPPORT CENTERS

For Sales, Service and Technical Support:

Reuter-Stokes

8499 Darrow Rd.

Twinsburg, Ohio 44087

U.S.A.

T: 888-242-3714

T: 330-425-3755

[www.reuter-stokes.com](http://www.reuter-stokes.com)

Technical content subject to change without notice.

# FS-9001OM

## Revision: U

