



# Flame Tracker

**Class I, Div I**

**Operation and Maintenance Manual**

Applicable to part numbers:

**RS-FS-9004**



 <b>Reuter-Stokes</b> <small>a Baker Hughes business</small>	NO.:	FS-9004OM		
	PAGE:	ii	OF	8
RS-FS-9004 User Manual	REV.:	K		

---

# **FS-9004OM**

**Revision: K**

**June 2023**

**8499 Darrow Road**

**Twinsburg, OH 44087**

	NO.:	FS-9004OM		
	PAGE:	iii	OF	8
RS-FS-9004 User Manual	REV.:	K		

This document and all information and expression contained herein are the property of Reuter-Stokes, LLC. and are provided to the recipient in confidence on a “need to know” basis. Your use of this document is strictly limited to a legitimate business purpose requiring the information contained therein. Your use of this document constitutes acceptance of these terms.

 <b>Reuter-Stokes</b> <small>a Baker Hughes business</small>	NO.:	FS-9004OM		
	PAGE:	iv	OF	8
RS-FS-9004 User Manual	REV.:	K		

---

Copyright © 2023 Baker Hughes Company. All rights reserved.

Contains Proprietary Information.

 <b>Reuter-Stokes</b> <small>a Baker Hughes business</small>	NO.:	FS-9004OM		
	PAGE:	v	OF	8
RS-FS-9004 User Manual	REV.:	K		

---

---

This page intentionally left blank.

 <b>Reuter-Stokes</b> <small>a Baker Hughes business</small>	NO.:	FS-9004OM		
	PAGE:	vi	OF	8
RS-FS-9004 User Manual	REV.:	K		

---

## CONTENTS

Contents..... vi

List of Figures..... vii

List of Tables .....viii

Important Information .....1

    Warnings and Cautions ..... 3

General Description ..... 4

Specifications..... 5

Interconnecting Cable..... 6

IS Barrier..... 8

Mechanical Dimensions.....10

Sensor..... 11

Installation .....13

    Mechanical.....13

    Electrical.....15

    Connector Pinout.....16

    Sensor Checkout .....17

    Controller Setup.....17

Maintenance .....18

Troubleshooting.....19

	NO.:	FS-9004OM		
	PAGE:	vii	OF	8
RS-FS-9004 User Manual	REV.:	K		

---

## LIST OF FIGURES

Figure 1: 4-20 mA Interconnect Cable .....	6
Figure 2: Recommended IS Barriers .....	8
Figure 3: Housing Side View.....	10
Figure 4: Housing Front View.....	10
Figure 5: Flame Sensor Wiring Diagram .....	12

 <b>Reuter-Stokes</b> <small>a Baker Hughes business</small>	NO.:	FS-9004OM		
	PAGE:	viii	OF	8
RS-FS-9004 User Manual	REV.:	K		

---

## LIST OF TABLES

Table 1: Available 4-20 mA Cables.....7

Table 2: Connector Pinout.....16

Table 3: Troubleshooting..... 20



	NO.:	FS-9004OM		
	PAGE:	1	OF	21
RS-FS-9004 User Manual	REV.:	K		

## IMPORTANT INFORMATION

All content and material in this manual (including, without limitation, text, design, graphics, logos, icons, images, code and software, as well as the selection and arrangement thereof) is confidential and proprietary, the exclusive property of and owned by Reuter-Stokes, Inc. and is protected by copyright, trademark and other applicable laws. Any use of content and material in this manual, including but not limited to the modification, distribution, transmission, performance, broadcast, publication, uploading, licensing, reverse engineering, transfer or sale of, or the creation of derivative works from, any material, information, software, products or services obtained from the content and material in this manual, or use thereof for purposes competitive to Reuter-Stokes, Inc., is expressly prohibited.

While every attempt has been made to assure the completeness, accuracy and timeliness of the content and material in this manual, it is provided on an “as is” and “as available” basis. Reuter-Stokes, Inc. expressly disclaims all warranties of any kind, whether express or implied, including but not limited to the implied warranties of merchantability and fitness for a particular purpose and any warranties that the content and material in this manual is non-infringing as well as warranties implied from a course of performance or course of dealing, the materials in this manual will be error-free, or that the materials in this manual will be complete, accurate or timely. No advice or information, obtained by you from Reuter-Stokes, Inc. or through the content and material in this manual shall create any warranty of any kind. Reuter-Stokes, Inc. does not make any warranties or representations regarding the use of the content and material in this manual in terms of its completeness, the use of the content, and material in this manual in terms of its completeness, correctness, accuracy, adequacy, usefulness, timeliness, reliability or otherwise.

	NO.:	FS-9004OM		
	PAGE:	2	OF	21
RS-FS-9004 User Manual	REV.:	K		

You acknowledge and agree that you assume full responsibility for your use of the content and material in this manual. You acknowledge and agree that your use of the content and material in this manual is at your own risk. You acknowledge and agree that, to the fullest extent permitted by applicable law, Reuter-Stokes, Inc. will not be liable for any direct, indirect, punitive, exemplary, incidental, special, consequential or other damages arising out of or in any way related to the content and material in this manual, whether based on contract, tort, strict liability, or otherwise. This disclaimer applies, without limitation, to any damages or injury arising from any failure of performance, error, omission, your loss of profits, destruction, and any other tangible or intangible loss.

If this equipment is used in a manner not specified by the manufacturer, the protection provided by the design of this equipment may be impaired.

This instrument contains no operator serviceable parts and should be serviced by qualified personnel only.

 <b>Reuter-Stokes</b> <small>a Baker Hughes business</small>	NO.:	FS-9004OM		
	PAGE:	3	OF	21
RS-FS-9004 User Manual	REV.:	K		

## WARNINGS AND CAUTIONS

Throughout this manual, when necessary, notes are used to identify considerations.

Definitions:



**WARNING:** DO NOT DISCONNECT CONNECTOR WHILE CIRCUIT IS ENERGIZED (OR LIVE), UNLESS AREA IS KNOWN TO BE NON-HAZARDOUS. (RISQUE D'EXPLOSION. NE PAS CONNECTER OU DÉBRANCHER LE CÂBLE LORSQU'IL EST ÉNERGÉTIQUE)

DO NOT INSTALL OR REMOVE THE FLAME SENSOR FROM THE SIGHT TUBE WITH THE COOLING COILS ATTACHED TO THE FLAME SENSOR. SENSOR DISASSEMBLY AND MALFUNCTION MAY OCCUR, POSSIBLY RESULTING IN A FALSE FLAME ON SIGNAL.

CERTIFICATIONS ARE BASED ON THE USE OF APPROVED CABLES ONLY. CURRENTLY AVAILABLE APPROVED CABLE ASSEMBLIES ARE BH REUTER STOKES RS-E2-0285PXXX.

DO NOT ATTEMPT TO DISASSEMBLE THE SENSOR. SENSOR IS NOT REPAIRABLE. ONCE THE SEAL HAS BEEN BROKEN IT CANNOT BE RESEALED.

DO NOT REMOVE THE SENSOR BY WRENCHING ON THE BODY. ALWAYS USE THE 1-1/2 HEX NUT. WRENCHING ON THE BODY MAY BREACH THE SEAL. BREACHING THE SEAL OF THE SENSOR WILL CAUSE LOSS OF THE INERT FILL GAS AND RENDER THE SENSOR UNUSABLE. ONCE THE SEAL HAS BEEN BROKEN IT CANNOT BE RESEALED.

DO NOT INSTALL A SENSOR THAT HAS A CRACKED WINDOW, DAMAGED THREADS OR THE ONE THAT HAS BEEN DISASSEMBLED.



**CAUTION:** THE FLAME SENSOR IS DESIGNED TO OPERATE AT EXTREME TEMPERATURES. DO NOT ATTEMPT TO WORK ON THE FLAME SENSOR UNTIL IT HAS REACHED A SAFE HANDLING TEMPERATURE.



**NOTE:** IDENTIFIES INFORMATION THAT IS CRITICAL FOR SUCCESSFUL APPLICATION AND UNDERSTANDING OF THE PRODUCT.

	NO.:	FS-9004OM		
	PAGE:	4	OF	21
RS-FS-9004 User Manual	REV.:	K		

## GENERAL DESCRIPTION

The Flame Tracker Lite is a rugged flame sensor that can operate in harsh industrial applications. The Reuter-Stokes technology has millions of operating hours and very high reliability. The sensor has high sensitivity and is tailored for use with hydrocarbon flames. It uses a silicon carbide sensing element for UV detection and has a single 4-20 mA current loop output. The Flame Tracker Lite can operate under high temperature and pressure and is constructed of corrosion resistant material. The sensor body is sealed and filled with dry argon.

The sensor circuit has a high initial gain, which automatically shifts to a lower gain in order to accommodate a wide range of input light level without saturating. The sensor regulates the supply current in proportion to the amount of UV light present. Both power and signal are transmitted on the same two wires. The sensor can be powered from a dc voltage between 12 and 30 volts.

The maximum operating temperature for the flame sensor is 120°C (248°F). Cooling systems are not applicable.

 <b>Reuter-Stokes</b> <small>a Baker Hughes business</small>	NO.:	FS-9004OM		
	PAGE:	5	OF	21
RS-FS-9004 User Manual	REV.:	K		

## SPECIFICATIONS

### Mechanical

Body Mount:	AISI316 Stainless Steel
Housing:	AISI304 Stainless Steel (sealed and Argon filled)
Connector	MIL-C-38999 Series III size 15 (5 pin)
Process:	3/4" NPT female
Sensor:	Silicon Carbide photodiode
Window:	Sapphire

### Operating

Sensitivity: RS-FS-9004	>5 mA @ $1 \times 10^{10}$ photons/in <sup>2</sup> /sec. @ 310 nm
Output:	4 - 20 mA dc, Max < 21 mA
Response time	<25 milliseconds
Power Requirements:	12 - 30 vdc @ > 100 mA Terminals isolated from case per EN 60079-II Section 6.3.12 (500 V <sub>r.m.s.</sub> )
Temperature Range (ambient):	-60°F to 302°F (-51°C to 150°C) 392°F (200°C) with specified water cooling
Relative Humidity	100% Non-Condensing
Process Pressure	400 psig (2.8 Mpa)

 <b>Reuter-Stokes</b> <small>a Baker Hughes business</small>	NO.:	FS-9004OM		
	PAGE:	6	OF	21
RS-FS-9004 User Manual	REV.:	K		

## INTERCONNECTING CABLE

The recommended cable to attach the flame sensor to the junction box is the RS-E2-O285PXXX. This is shown in Figure 1. Dimensions shown are in inches (mm) and are reference only.

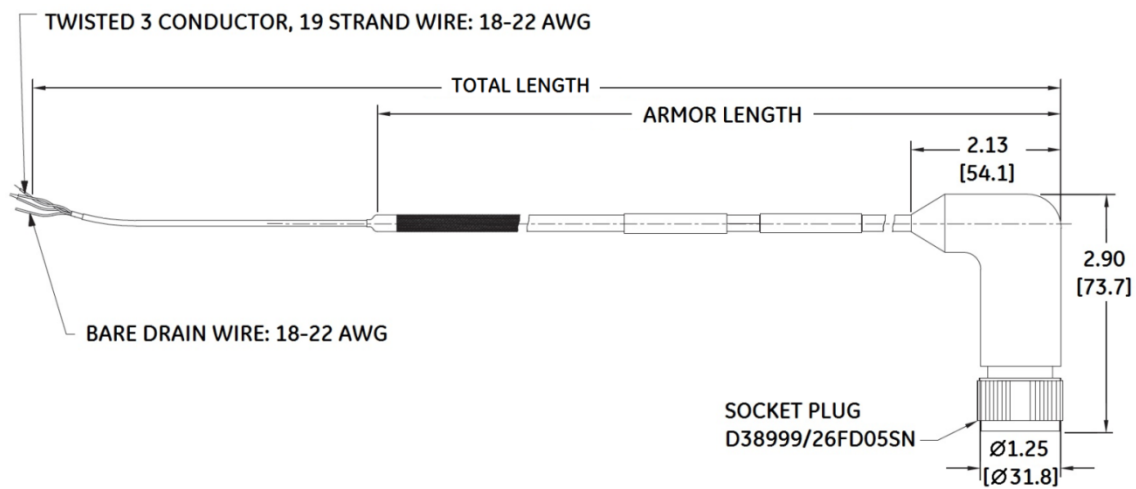

Figure 1: 4-20 mA Interconnect Cable

Connector : MIL-DTL-38999 series III, shell size 15, 5 #16 pins

Voltage (max) : 300 VRMS

Temperature (max) : 482°F (250°C)

Dimensions in inches [millimeters]

Dimensions are for reference only

 <b>Reuter-Stokes</b> <small>a Baker Hughes business</small>	NO.:	FS-9004OM		
	PAGE:	7	OF	21
RS-FS-9004 User Manual	REV.:	K		

The available cable part numbers are listed in Table .

Interconnecting Cable Part Number	Total Length ft [m]	Armor Length in [cm]	Connector Type
RS-E2-0285P001	60-62 [18.3-18.9]	36 [14.2]	Right Angle
RS-E2-0285P003	60-62 [18.3-18.9]	75 [190.5]	Right Angle
RS-E2-0285P004	120-123 [36.6-37.2]	36 [14.2]	Right Angle
RS-E2-0285P021	15-17 [11.9-12.50]	36 [14.2]	Right Angle
RS-E2-0285P011	60-62 [18.3-18.9]	36 [14.2]	Straight
RS-E2-0285P012	120-122 [36.6-37.2]	36 [14.2]	Straight
RS-E2-0285P013	60-62 [18.3-18.9]	96 [243.84]	Straight
RS-E2-0285P010	60-62 [18.3-18.9]	120 [304.8]	Straight

Table 1: Available 4-20 mA Cables

 <b>Reuter-Stokes</b> <small>a Baker Hughes business</small>	NO.:	FS-9004OM		
	PAGE:	8	OF	21
RS-FS-9004 User Manual	REV.:	K		

## IS BARRIER

Figure 2 shows two recommended safety barriers.

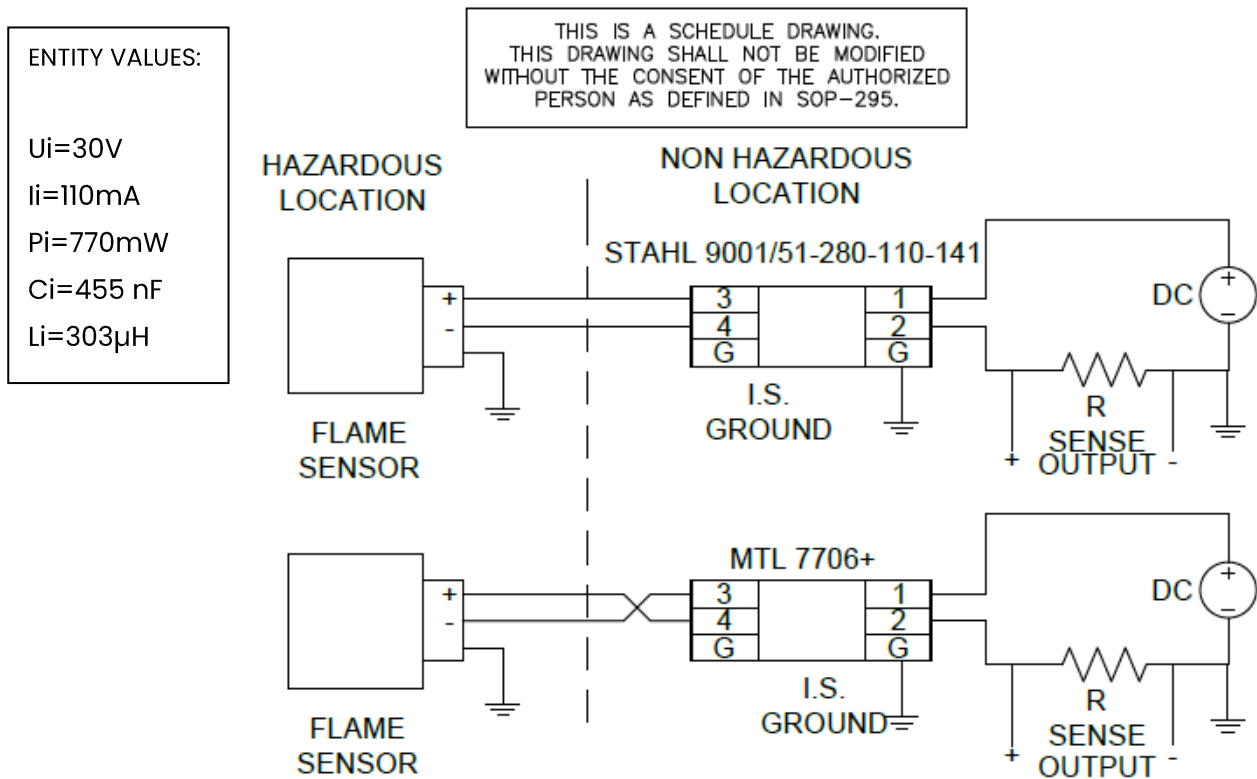



Figure 2: Recommended IS Barriers



### NOTES:

1. ENTITY PARAMETERS ARE APPLICABLE TO MEET THE REQUIREMENT OF TYPE OF PROTECTION Ex ia. STAHL 9001/51-280-110-141 AND MTL 7706+ ARE THE SUGGESTED INTRINSICALLY SAFE BARRIER; OTHER EQUIVALENT BARRIERS CAN BE USED.



 <b>Reuter-Stokes</b> <small>a Baker Hughes business</small>	NO.:	FS-9004OM		
	PAGE:	9	OF	21
RS-FS-9004 User Manual	REV.:	K		

2. THE ENTITY PARAMETERS OF THE SENSOR LISTS THE INDUCTANCE AS  $L_i=303\mu\text{H}$  THIS VALUE INCLUDES THE INDUCTANCE OF A STANDARD REUTER-STOKES INTERFACE CABLE, PART NUMBERS RS-E2-0285P004 AND RS-E2-0285P012 WITH LENGTH 122FEET. THE  $L_i$  VALUE OF THE FLAME SENSOR DEVICE EXCLUDING CABLES IS  $0\mu\text{H}$ . THIS IS AN IMPORTANT DISTINCTION WHEN EVALUATING THE ENTITY PARAMETERS OF THE SAFETY BARRIERS AND CABLES USING MIXED CIRCUIT RULE OF IEC 60079-11-2011. WITH  $L_i=0$  THE FULL AMOUNT FOR  $L_o$  AND  $C_o$  FROM ANNEX A IGNITION CURVES IS ALLOWABLE.
  
3. THE PROCESS OF MATCHING UP THE ASSOCIATED APPARATUS AND INTRINSICALLY SAFE DEVICE IS OFTEN SUMMARIZED AS FOLLOW:  $U_o \leq U_i$ ,  $I_o \leq I_i$ ,  $P_o \leq P_i$ ,  $C_o \geq C_i + C_{\text{cable}}$ ,  $L_o \geq L_i + L_{\text{cable}}$

 <b>Reuter-Stokes</b> <small>a Baker Hughes business</small>	NO.:	FS-9004OM		
	PAGE:	10	OF	21
RS-FS-9004 User Manual	REV.:	K		

### MECHANICAL DIMENSIONS

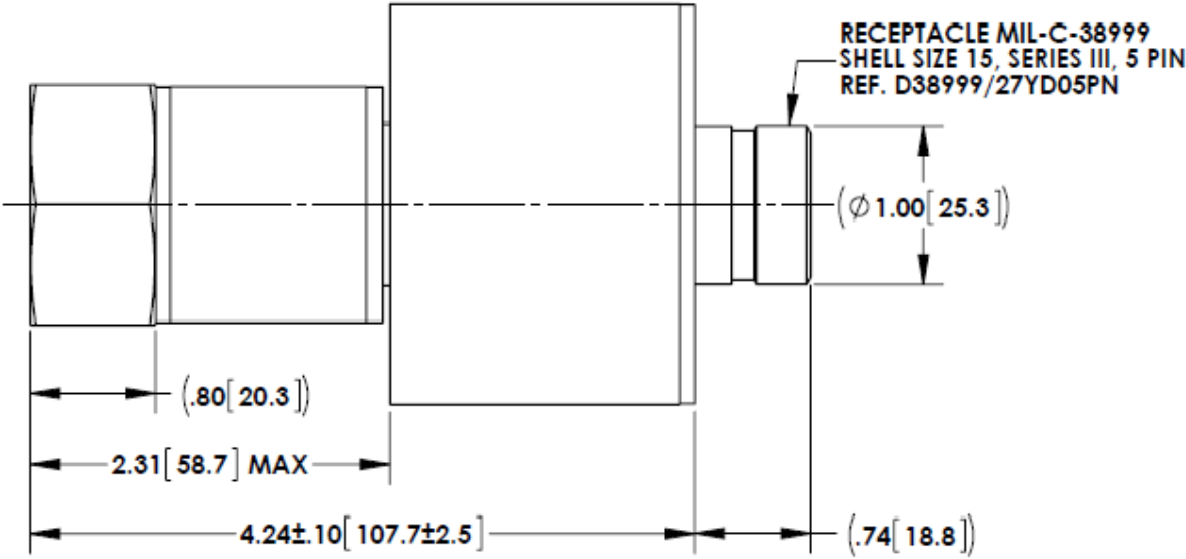

Figure 3: Housing Side View

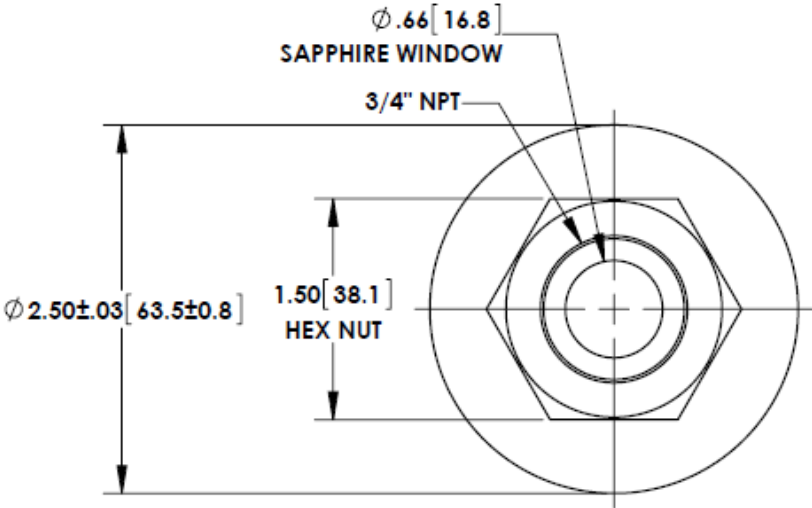



Figure 4: Housing Front View

	NO.:	FS-9004OM		
	PAGE:	11	OF	21
RS-FS-9004 User Manual	REV.:	K		

## SENSOR

Figure 5 is a block diagram of the Flame Sensor. The sensor has a sapphire window that is transparent to UV light and can withstand the compressor discharge temperature and pressure. It has a lens inside that focuses the light on a silicon carbide photodiode in a hermetic package. The photodiode is wired to a MOSFET input amplifier. The amplifier has a high initial gain, which automatically shifts to a lower gain in order to accommodate a wide range of input light level without saturating. The sensor regulates the supply current in proportion to the amount of UV light present. Both power and signal are transmitted on the same two wires. The sensor can be powered from a dc voltage between 12 and 30 volts. The whole transducer is sealed and filled with dry argon.

SiC FLAME SENSOR

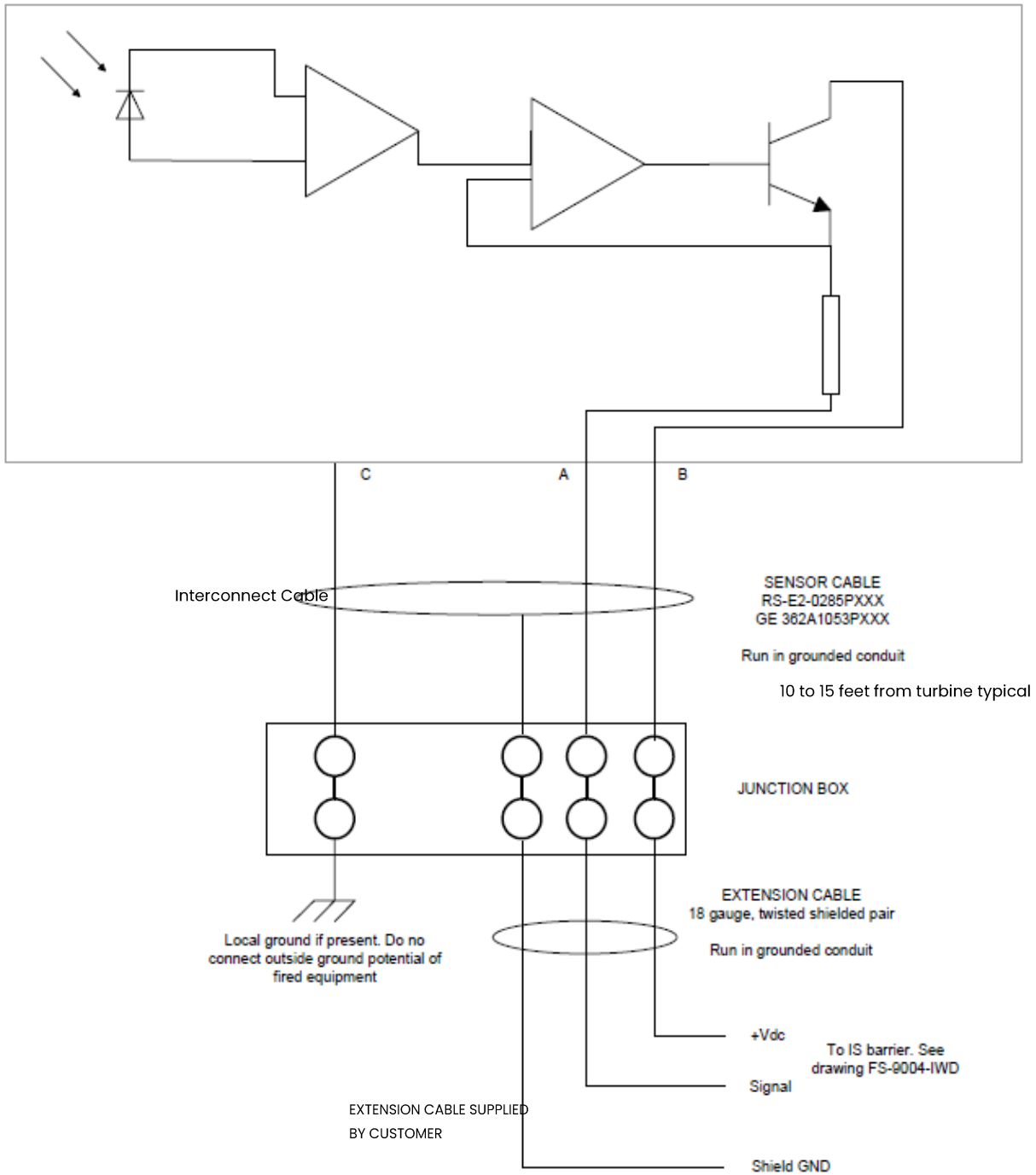



Figure 5: Flame Sensor Wiring Diagram

	NO.:	FS-9004OM		
	PAGE:	13	OF	21
RS-FS-9004 User Manual	REV.:	K		

## INSTALLATION

### MECHANICAL

The maximum operating temperature for the flame sensor is 302° F (150° C). If the peak ambient temperature at the location of the sensor exceeds this then cooling will be required. There are three methods available for cooling: Water-cooling, air-cooling with ambient air, and air-cooling with pressurized air.

Water-cooling requires the use of a water-cooling coil Part Number SP-566, GE Part Number 353B3490G001. The water-cooling coil requires water at a temperature of 50° F to 135° F (10° C to 57° C) at a flow rate of 1.0 gpm (3.8 lpm) per sensor. When using water-cooling the flame sensor can be operated to an ambient temperature of (455°F) 235°C.

Air-cooling with ambient air can be used in installations where the enclosure is cooled with forced air. This would be typical of LM2500 and LM6000 aircraft engine applications. The air velocity at the sensor must be 5 ft/sec (1.5 m/sec), or greater, at a temperature of 50° F (10° C), or less, above outside ambient. Under these conditions the sensors will operate at outside ambient temperatures up to 140° F (60° C).

Air-cooling with pressurized air requires the use of Air-Cooling Can. Reuter-Stokes Part Number RS-E2-0259 (GE Part Number 07482SOCNL4482IP01). The Air-Cooling Can is installed in the same manner as the water-cooling coil. The Air-Cooling Can requires 25 psi (170 kPa) minimum at 120° F (49° C) maximum.

Do not complete step 3 of the following instructions at this time. Leave the sensors installed hand tight until after the sensor checkout described in Section 3.4.

FLAME SENSOR AND WATER COOLING JACKET INSTALLATION INSTRUCTIONS

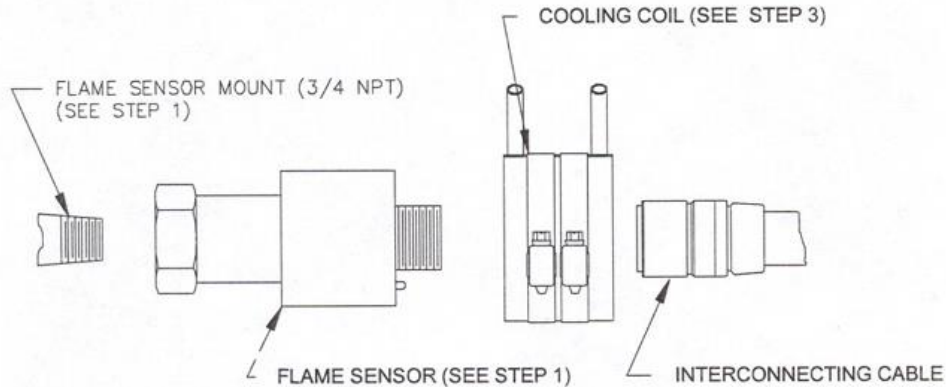

1. Ensure that the cooling coil is not attached to the flame sensor during installation or removal of the sensor. The cooling coil can apply an unwanted torque and cause disassembly and malfunction of the flame sensor.
2. Apply a small amount of Never-Seez PN NG-165 to threads of sight tube prior to installation. Be sure the Never-Seez applied to the sight tube is minimal and only applied below the 2nd thread. If Never-Seez is applied to the face of the sight tube, upon heating, it can fog the window of the Flame Sensor.
3. Inspect the window and clean with Isopropanol soaked swab, If required. Install hand tight (3-4 Full turns) tighten with a wrench approximately 2.5 turns. Tighten further as required to align keys on cable connector with slots in sensor connector.
4. Slide cooling coil over Flame Sensor major diameter and orient tubes on the coils required for assembly. Tighten clamps 50-60 in LBS. Install Swagelok fittings. RE-torque clamps to 50-60 in LBS after first shut down.
5. Slide cooling coil over Flame Sensor major diameter and orient tubes on the coil as required for assembly. Tighten clamps 50-60 in. lbs. Install Swagelok fittings re-torque clamps to 50-60 in. lbs. after first shut down.

 <b>Reuter-Stokes</b> <small>a Baker Hughes business</small>	NO.:	FS-9004OM		
	PAGE:	15	OF	21
RS-FS-9004 User Manual	REV.:	K		



**Note:** 50 - 60 in. lbs = 5.6 - 6.8 Nm. When installing the Water Cooling Coil, ensure that the edge of the Sheet Metal Band is not in contact with the cooling tubes. This will ensure that no rubbing or fretting of the cooling tubes by the band's edge will occur during turbine operation.

## ELECTRICAL

The sensors are connected to the turbine junction box with connector cable RS-E2-0285PXXX or 362A1053PXXX. The RS-E2-0285 consists of black, white and green wires twisted and shielded. All wiring must be in grounded conduit. The green wire must be connected to earth ground at the junction box. Do not connect the shields to each other or to earth ground at any location. The shields should be individually jumped through all junction boxes and connected to the proper ground terminal at the Controller. The polarity of the cable is as follows; white is positive and black is negative/signal return. Reverse polarity will not damage the sensor. Signal cable from the junction box to the Controller should be 18 gauge (1.02 mm) twisted shielded pair. The extension cable from the junction box to the Controller is the customer's responsibility.

The Flame Tracker™ is connected to the controller through an active intrinsically safe barrier. Do not use passive barriers since they will prevent the sensor from operating properly. The two recommended barriers are the STAHL 9001/51-280-110-141 and the MTL 7706+. They can be operated from any well-filtered dc supply from 20 volts to 35 volts. The supply should be capable of supplying 100 milliamps and should be current limited. The maximum value for the sense resistor plus the wire resistance for the STAHL barrier is 750 ohms and for the MTL barrier is 500 ohms. See drawing FS-9004-IWD on page 3 for installation.

 <b>Reuter-Stokes</b> <small>a Baker Hughes business</small>	NO.:	FS-9004OM		
	PAGE:	16	OF	21
RS-FS-9004 User Manual	REV.:	K		

**CONNECTOR PINOUT**

The pinout for the power connector is shown in Table .

<b>Interconnecting Cable Pinout</b>		
<b>PIN</b>	<b>CIRCUIT DESIGNATION</b>	<b>WIRE COLOR for RS-E2-0285PXXX cable</b>
A	-	Black
B	+	White
C	Ground	Green
D	Not Used	
E	Not Used	

Table 2: Connector Pinout



	NO.:	FS-9004OM		
	PAGE:	17	OF	21
RS-FS-9004 User Manual	REV.:	K		

## SENSOR CHECKOUT

Disconnect the sensors and unscrew them from the turbine. Plug the sensor cables back in to each of the sensors. Apply power to the sensors. Check the current values at the controller for each of the sensors. The sensors are sensitive to light, and may have some reading, depending on the ambient light level. Test each sensor by covering the port to see the zero flame intensity signal, and with a flashlight to see a positive reading. With no light the reading should be 3.7 to 4.1 milliamps, while with most flashlights the reading should be above 8 milliamps. An LED flashlight may not work for this application. Variations in flashlight type, strength, or battery voltage may cause variation in signal output. The flashlight test is intended as a field test for general functionality only and is not a controlled or quantitative test. If a sensor is outside these rough check limits see Section 5.0.

Disconnect the sensor cables, and reinstall the sensors according to the instruction in Section 3.1. At this time step 2 of Section 3.1 should be completed and the sensor cables reconnected. Make sure that the sapphire window is clean; if it needs cleaning, do this according to the maintenance instructions in Section 4.0. Check that all sensors are reading between 3.7 and 4.1 milliamps.

## CONTROLLER SETUP

The Flame Sensor provides a minimum output of 5 milliamps when exposed to the minimum flame intensity specified in GE specification number 362A1052. The set point for flame off should be set to 6.25%, which is equal to 5 milliamps. The set point for flame on should be 10%, which equals 5.6 milliamps. If the intensity levels are too low for these settings there may be other problems. Low intensity levels may be a sign of other problems. Refer to the Troubleshooting section.

 <b>Reuter-Stokes</b> <small>a Baker Hughes business</small>	NO.:	FS-9004OM		
	PAGE:	18	OF	21
RS-FS-9004 User Manual	REV.:	K		

## MAINTENANCE



**WARNING:** Do not disconnect connector while circuit is energized (or live), unless area is known to be non-hazardous. (RISQUE D'EXPLOSION. NE PAS CONNECTER OU DÉBRANCHER LE CÂBLE LORSQU'IL EST ÉNERGÉTIQUE)



**CAUTION:** The operating temperature range of the Flame Sensor is -60°F to 302°F (-51°C to 150°C). Do not attempt to work on the Flame Sensor or the cable until they have reached to a safe handling temperature.

The Flame Sensor output will deteriorate as the lens becomes dirty. It is recommended, when initially installed, that the signal level be recorded during normal operation. During subsequent running, the signal level should be compared with the initial values. If a significant reduction in the signal level is noticed, then it is recommended that the lens be cleaned at the next opportunity (with the turbine shut down and cold). Clean the lens with isopropyl alcohol or other residue free solvent compatible with Sapphire. In order to reduce the risk of galling, an anti seize compound should be applied to the mounting thread prior to reinstallation of the sensor.

 <b>Reuter-Stokes</b> <small>a Baker Hughes business</small>	NO.:	FS-9004OM		
	PAGE:	19	OF	21
RS-FS-9004 User Manual	REV.:	K		

## TROUBLESHOOTING



**WARNING:** Do not disconnect connector while circuit is energized (or live), unless area is known to be non-hazardous and free of explosive gases. (RISQUE D'EXPLOSION. NE PAS CONNECTER OU DÉBRANCHER LE CÂBLE LORSQU'IL EST ÉNERGÉTIQUE)



**CAUTION:** The flame sensor operates at extreme temperatures. Do not attempt to work on the flame sensor until it has reached a safe handling temperature.

Problem	Cause	Solution
No current flows	<ol style="list-style-type: none"> <li>1. Reversed polarity</li> <li>2. Open wire</li> <li>3. No 12-30V supply</li> </ol>	<ol style="list-style-type: none"> <li>1. Change polarity at junction box</li> <li>2. Check connections at junction box</li> <li>3. Check voltage supply to ensure power is reaching sensor</li> </ol>
Low sensitivity during checkout or operation	<ol style="list-style-type: none"> <li>1. Dirty window</li> <li>2. Grounded cable</li> <li>3. Sight tube not torqued</li> </ol>	<ol style="list-style-type: none"> <li>1. Clean window (See Maintenance section)</li> <li>2. Check cables for grounds</li> <li>3. Check torque, torque to specified values</li> </ol>
Low flame intensity signal during operation	<ol style="list-style-type: none"> <li>1. Misalignment of the sight tube</li> <li>2. Dirty window</li> <li>3. Tube not torqued</li> </ol>	<ol style="list-style-type: none"> <li>1. Check the squareness of all sight tube flanges</li> <li>2. Verify that the sensors have a clear view of the flame.</li> <li>3. Ensure sight tube is torqued</li> </ol>

 <b>Reuter-Stokes</b> <small>a Baker Hughes business</small>	NO.:	FS-9004OM		
	PAGE:	20	OF	21
RS-FS-9004 User Manual	REV.:	K		

Periodic low reading on secondaries of DLNI turbines	<ol style="list-style-type: none"> <li>1. Condensation on the sensor window that can occur under high humidity situations.</li> </ol>	<ol style="list-style-type: none"> <li>1. A shorter mount tube (PN# EI-0058P002), available from Reuter-Stokes may improve this condition. Please contact Reuter Stokes for further information.</li> </ol>
No flame indication	<ol style="list-style-type: none"> <li>1. Cable connection open</li> <li>2. Open wire</li> <li>3. No-12-30V supply</li> </ol>	<ol style="list-style-type: none"> <li>1. Check connections at junction box</li> <li>2. Check voltage supply to ensure power is reaching sensor</li> <li>3. Check voltage supply to ensure power is reaching sensor</li> </ol>

Table 3: Troubleshooting

 <b>Reuter-Stokes</b> <small>a Baker Hughes business</small>	NO.:	FS-9004OM		
	PAGE:	21	OF	21
RS-FS-9004 User Manual	REV.:	K		

Customer Support Centers

For Sales, Service and Technical Support:

Reuter-Stokes

8499 Darrow Rd.

Twinsburg, Ohio 44087

U.S.A.

T: 888-242-3714

T: 330-425-3755

[www.reuter-stokes.com](http://www.reuter-stokes.com)

Technical content subject to change without notice.

**FS-9004OM**

**Revision: K**

