

REVISIONS			
REV.	DESCRIPTION	RESPONSIBLE ENGINEER	DATE PREPARED
F	ECM 500000527955	R. LUCARELLI	07-24-2024

NOTES FOR COOL END:

- COMPONENT IDENTIFICATION
 - MANUFACTURER'S NAME OR CODE. REUTER-STOKES ADDRESS
 - CUSTOMER PART NO.
MANUFACTURER PART NUMBER: RS-FS-9010-03 OR RS-FS-9010-03-25X
 - SERIAL NUMBER
 - ETL LISTED
CLASS 1, DIVISION 1, GROUPS C,D T3
 - INDUSTRIAL CONTROL EQUIPMENT FOR USE IN HAZARDOUS LOCATIONS (INTRINSICALLY SAFE).
 - ATEX/IECEx
- MATING CABLE: REUTER-STOKES RS-E2-0285PXXX.

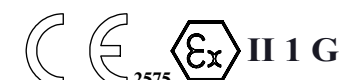

Ex ia IIB T3 Ga

- OPERATING TEMPERATURE RANGE: 104 °F TO 284 °F [40 °C TO 150 °C]
- SURVIVABLE TEMPERATURE RANGE: -60 °F TO 302 °F [-51 °C TO 150 °C]
- MAXIMUM VOLTAGE: 30VDC

NOTES FOR HOT END:

- COMPONENT IDENTIFICATION
 - INDUSTRIAL CONTROL EQUIPMENT FOR USE IN HAZARDOUS LOCATIONS (NORMALLY NONARCING COMPONENT).
 - OPERATING TEMPERATURE RANGE:
3/4 NPT MOUNT END: 104 F TO 617 F [40 C TO 325 C]
CABLE CONNECTOR END: 104 F TO 302 F [40 C TO 140 C]
 - SURVIVABLE TEMPERATURE RANGE:
3/4 NPT MOUNT END: -60 F TO 617 F [-51 C TO 325 C]
CABLE CONNECTOR END: -60 F TO 302 F [-51 C TO 150 C]
- HOT END CABLE MINIMUM BEND RADIUS: 6.0 INCHES [152.4 MM].

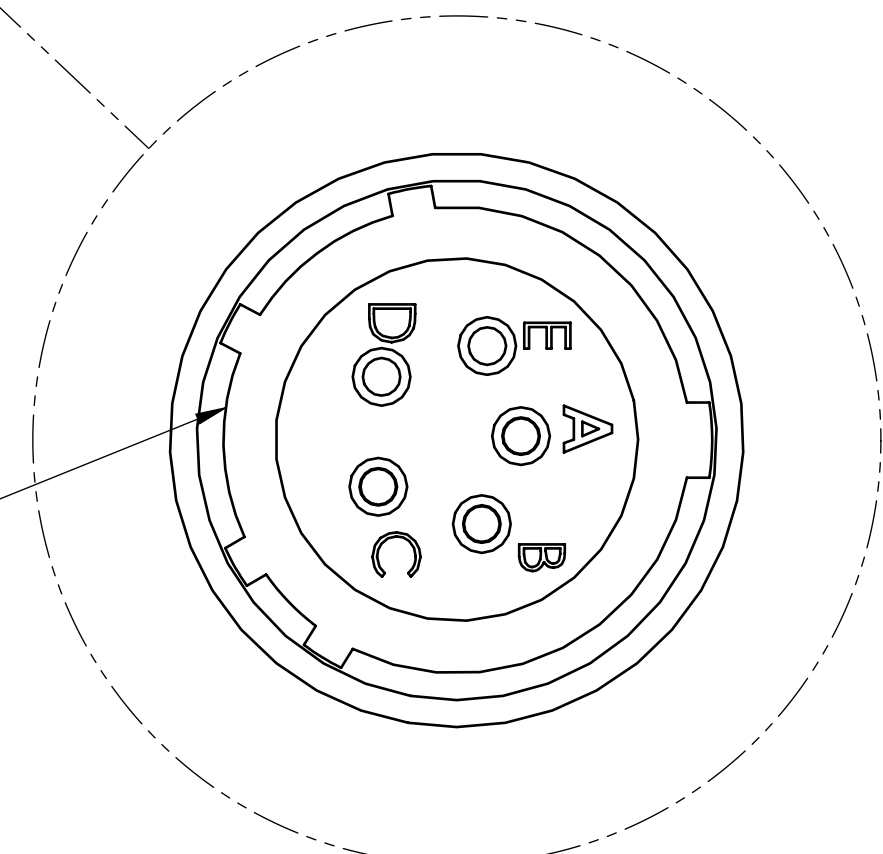
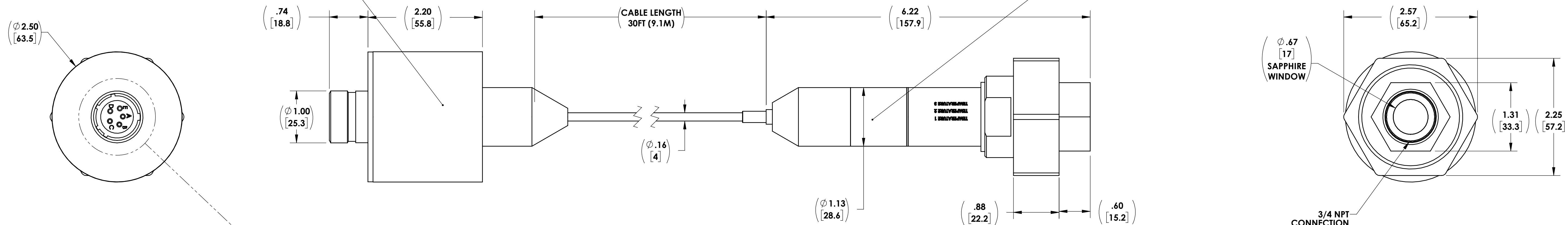
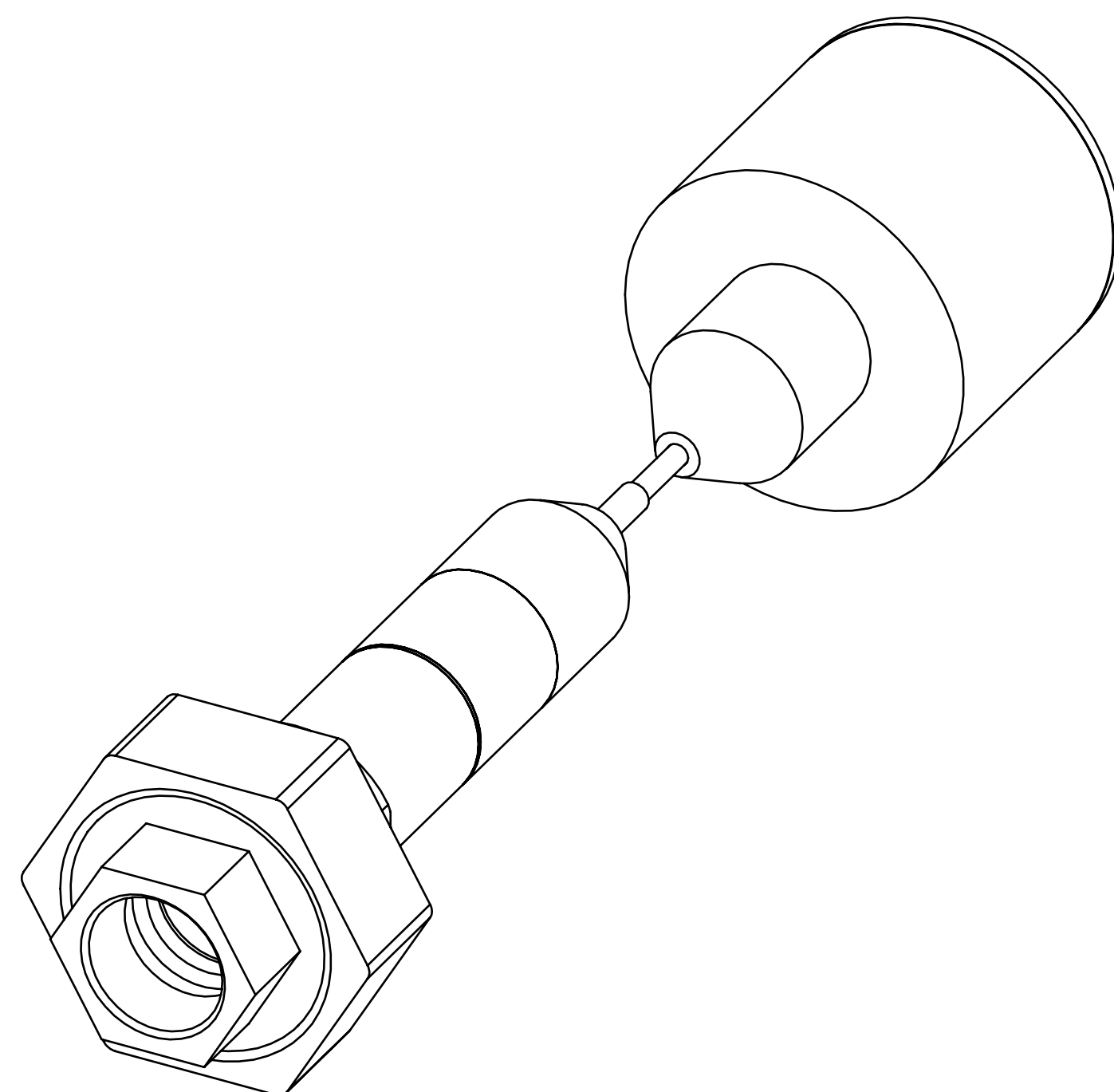

DETAIL A
SCALE 3 : 1

CONNECTOR LEGEND	
PIN	CIRCUIT DESIGNATION
A	-
B	+
C	GROUND
D	NOT USED
E	NOT USED

DRAWING APPLICATION RANGE

NO.	PART NUMBER	DESCRIPTION	CABLE LENGTH
1	RS-FS-9010-03	FTD325 ZONE 0 HAZARD	359 IN (9.1 M)
2	RS-FS-9010-03-25X	FTD325 ZONE 0 HAZARD W/ 2.5X GAIN	359 IN (9.1 M)

OPERATIONAL NOTES:

- REFERENCE OPERATION & MAINTENANCE MANUAL FS-9010OM.
- REFERENCE QUICK START MANUAL FS-9010QSM.

DIMENSIONS SHOWN IN INCHES [MILLIMETERS]

LIST OF MATERIAL OR PARTS	
CONFORMS TO ASME Y14.5M-1994 STDs UNLESS OTHERWISE SPECIFIED DIMENSIONAL TOLERANCES:	APPLIED PRACTICES SOP-121.4
.X DECIMAL ±.1 XXX ±.005	RESPONSIBLE ENGINEER/CREATION DATE
.XX DECIMAL ±.01 .XXX ±.0005	R. AUSTIN 1-13-2017
ANGULAR ±2 SURFACE FINISH 125	GA APPROVED
FILLET CHAMFER	NA
DIMENSIONS ARE IN INCHES	INITIAL ECN
MATERIAL SEE BOM	500000239914
THIRD ANGLE PROJECTION	
SIZE D	DWG NO
SCALE 1:1	RS-FS-9010-03
	REV F
THIS DOCUMENT CONTAINS PROPRIETARY INFORMATION DIRECTLY LINKED INTO THE SAP SYSTEM	
SHEET 1 OF 1	